

Front Brush Guard Kit

BM23365



JOHN DEERE

INSTALLATION INSTRUCTIONS

Front Brush Guard Kit

M162181 09APR20 (ENGLISH)

**XUV550, XUV550 S4, XUV560, XUV560 S4, XUV560E,
XUV560E S4, XUV590E, XUV590E S4, XUV590M,
XUV590M S4 Gator™ Utility Vehicles**

**John Deere Horicon Works
M162181 (09APR20)**

PRINTED IN U.S.A.
COPYRIGHT © 2020
DEERE & COMPANY
Moline, Illinois

All rights reserved.
A John Deere ILLUSTRATION™ Manual
Previous Editions
Copyright © 2016, 2018

M162181-19-09APR20

Parts in Kit

Quantity	Description
1	Left Brush Guard
1	Right Brush Guard
1	Center Brush Guard
2	Bumper Plug
2	Corner Plug
2	Clevis Pin
4	Screw, M8x20
4	Bolt, M12x30
4	Locknut, M12
2	Brush Guard Edge Cover (Included for European Homologated Machines Only)

NOTE: Retain these installation instructions with your machine operator's manual.

BVVM5IT,0000237 -19-09APR20-1/1

Parking Safely

Park the machine safely. See Parking Safely in your Operator's Manual.

MX88017,0000007 -19-17OCT19-1/1

Install Kit

1. Position the left brush guard (A) against the front frame extension and loosely install screws, M8x20 (B).
2. Install a bolt, M12x30 (C) through the bottom guard mounting plate and bottom panel (D). Secure with a M12 locknut.
3. Tighten the screws (B) and M12 locknut to a specification.

Specification

Screw, M8x20—Torque.....32.1 N·m
(24 lb-ft)

Specification

Locknut, M12—Torque.....110 N·m
(81 lb-ft)

4. Install a bumper plug (E) in the end of the brush guard tube until flush.
5. Repeat steps for installation of the right brush guard to the front frame extension.

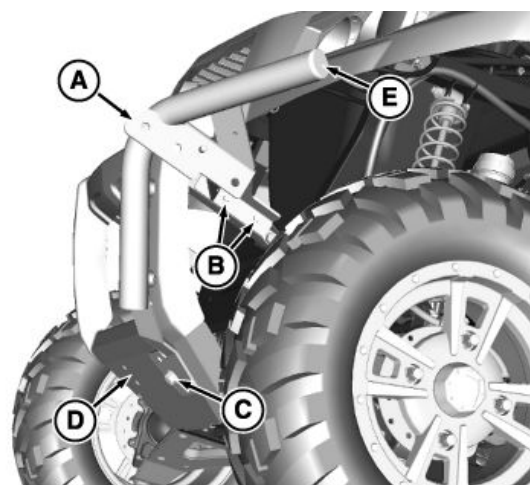

A—Left Brush Guard
B—Screw, M8x20 (4 used)
C—Bolt, M12x30 (2 used)
D—Bottom Panel
E—Bumper Plug

MXT023116—UN—23AUG18

Continued on next page

BVVM5IT,0000238 -19-09APR20-1/3

6. Position the center brush guard (A) on the machine. Install clevis pins (B), and secure the center guard to the left and right guards.
7. Install a M12x30 bolt (C) through the center and left brush guards and loosely secure with a M12 locknut.
8. Install a M12x30 bolt (D) through the center and right brush guards and loosely secure with a M12 locknut.
9. Tighten both M12 locknuts enough to allow the brush guard assembly to rotate when the clevis pins (B) are removed.

A—Center Brush Guard
B—Clevis Pin (2 used)

C—Bolt, M12x30
D—Bolt, M12x30

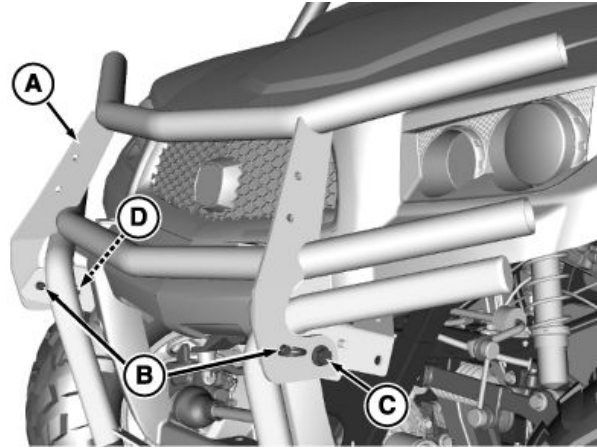

MXT023117 —UN—23AUG18

BVMSIT,0000238 -19-09APR20-2/3

10. Install a corner plug (A) on each side of brush guard assembly.

NOTE: Brush guard edge covers are required for European homologated machines only.

11. For European Homologated Machines:

Install a brush guard edge cover onto each brush guard bracket (B).

A—Corner Plug (2 used)

B—Brush Guard Bracket

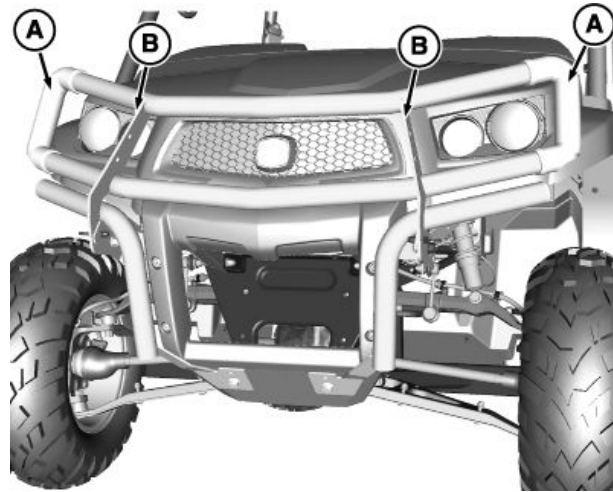

MXT023118 —UN—23AUG18

BVMSIT,0000238 -19-09APR20-3/3