

# Protective Structure Kit

BUC10226



**JOHN DEERE**

## INSTALLATION INSTRUCTIONS

### Protective Structure Kit

UC14196 18JAN19 (ENGLISH)

**XUV550, XUV560, and XUV590i Gator™ Utility Vehicles**

**John Deere Horicon Works**  
**UC14196 (18JAN19)**

PRINTED IN U.S.A.  
COPYRIGHT © 2019  
DEERE & COMPANY  
Moline, Illinois

All rights reserved.  
A John Deere ILLUSTRATION™ Manual  
Previous Editions  
Copyright © 2017

UC14196-19-18JAN19



**Parts In Kit**

Quantity	Description
1	Cross Tube, Rear (A)
1	Cross Tube, Front (B)
1	Frame, Left (C)
1	Frame, Right (D)
2	Retractor, Seat Belt
1	Buckle, Seat Belt (with switch and harness)
1	Buckle, Seat Belt (without switch and harness)
1	Label
2	Bolt, M12x30 (XUV 550 Only)
4	Bolt, M12x32 Shoulder
8	Bolt, Flange M12x30
10	Bolt, Flange M12x35
24	Locknut, M12
2	Washer, M13
2	Nut, M5
2	Screw, M5x30
2	Wave Spring
1	Light, Brake/Tail
1	Harness, Rear Protective Structure Lights

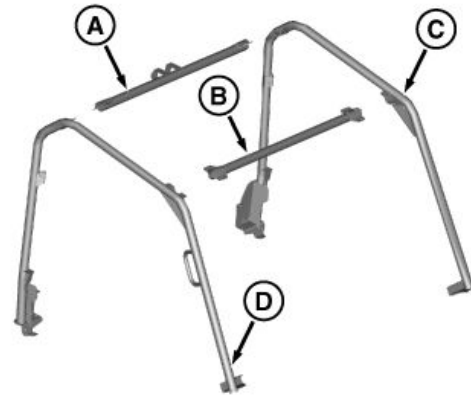

**A—Cross Tube, Rear  
B—Cross Tube, Front**

**C—Frame, Left  
D—Frame, Right**

*NOTE: Retain these installation instructions with the machine operator's manual.*

MX52301.0001354 -19-18JAN19-1/1

MX1018689—UN—07JUL16

### Parking Safely

1. Stop vehicle on a level surface, not on a slope.
2. Fully lower any attachments on the machine that can be lowered.
3. Lock park brake.
4. Stop engine.
5. Remove key.
6. Before you leave the operator's seat, wait for engine and all moving parts to stop.
7. Disconnect the negative battery cable or remove the spark plug wire (for gasoline engines) before servicing the machine.

OUO2005,0000493 -19-09NOV15-1/1

### Prepare Machine

1. Secure cargo box in raised position.
2. Park machine safely. (See Parking Safely.)
3. Disconnect wiring and remove any kits installed on Protective Structure.
4. Remove roof if installed.

### Remove Side Panels

1. Remove six screws (A) from left side panel (B).

A—Screw

B—Panel, Left Side

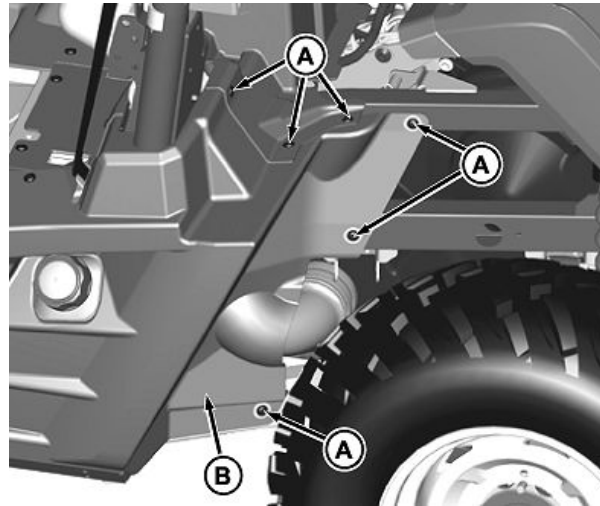

MXTD16382—JUN—05NOV15

Continued on next page

MX52301,0000F5C -19-30JUN16-1/7

**⚠ CAUTION: Avoid injury! Gasoline is extremely flammable. DO NOT SMOKE. Always work in a well-ventilated area away from open flame or spark-producing equipment, including equipment that utilizes pilot lights.**

2. Remove fuel filler cap (A).
3. Remove screw (B) and raise seat.
4. Remove five (550 and 560) or six (590i only) screws (C) and left side panel (D).
5. Install fuel filler cap.
6. Remove twelve screws and right side panel.

A—Fuel Filler Cap  
B—Screw

C—Screw, M10 Self-Tapping  
D—Panel, Left Side

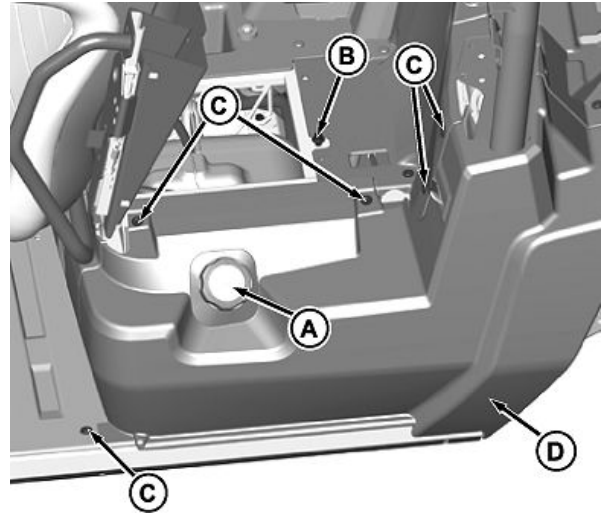

XUV560 Shown

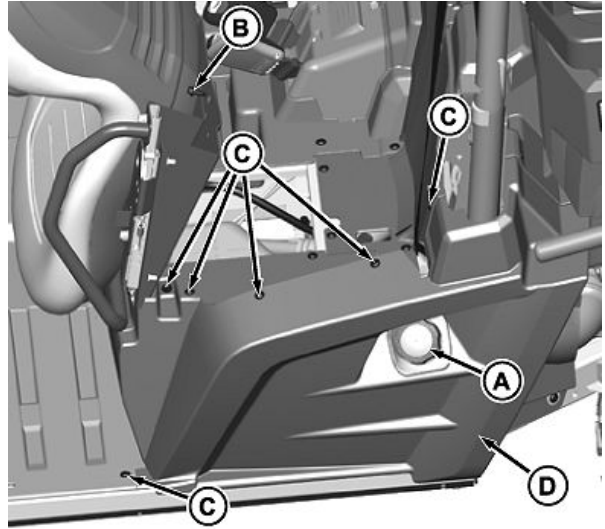

XUV590i Shown

Continued on next page

MX52301,0000F5C -19-30JUN16-2/7

MXT016617 —UN—30NOV15

MXT016383 —UN—12NOV15

### Remove Center Seat Closeout Panels

1. Push tab (A) and remove cover (B).
2. Remove seven screws (C) and center panel (D).

A—Tab  
B—Cover

C—Screw  
D—Center Panel

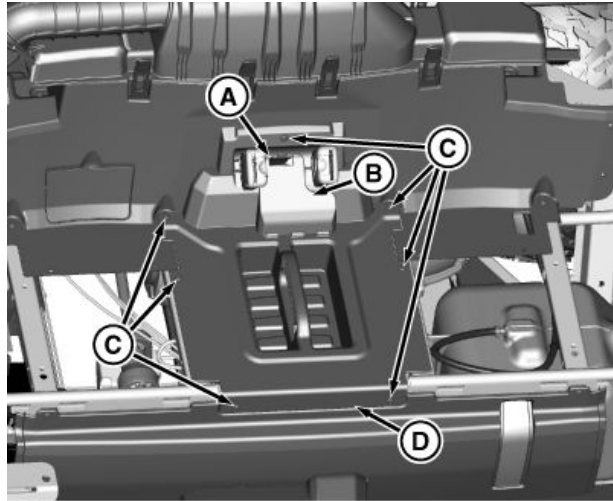

XUV550 Shown

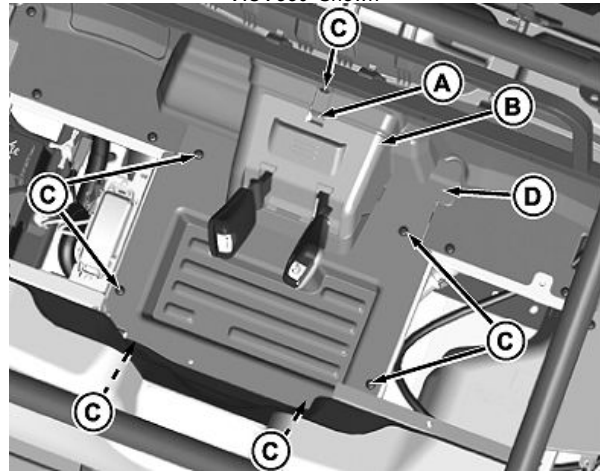

XUV560 and XUV590i Shown

MXT018673 — UN — 29JUN16

MXT016385 — UN — 29JUN16

MX52301,0000F5C -19-30JUN16-3/7

3. Remove eleven screws (A) from air plenum (B).

A—Screw

B—Air Plenum

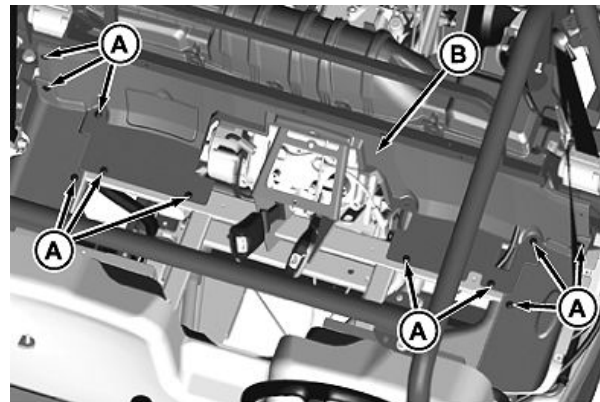

MXT016386 — UN — 06NOV15

Continued on next page

MX52301,0000F5C -19-30JUN16-4/7

**Disconnect Air Plenum**

1. Lift on eight tabs (A) and remove air plenum cover (B).

A—Tab

B—Cover, Air Plenum

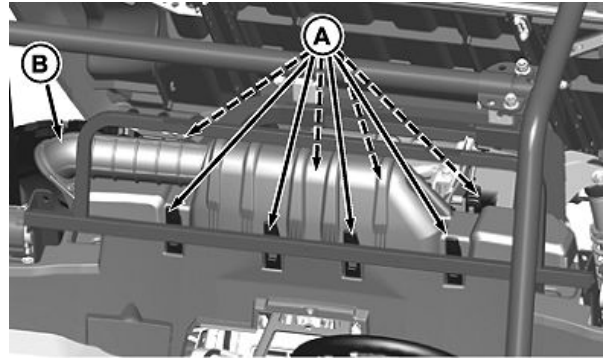

MXT016387—UN—05NOV15

MX52301,0000F5C -19-30JUN16-5/7

2. Remove three screws (A), cover (B), and gasket.
3. Remove air filter (C).

A—Screw  
B—Cover

C—Filter, Air

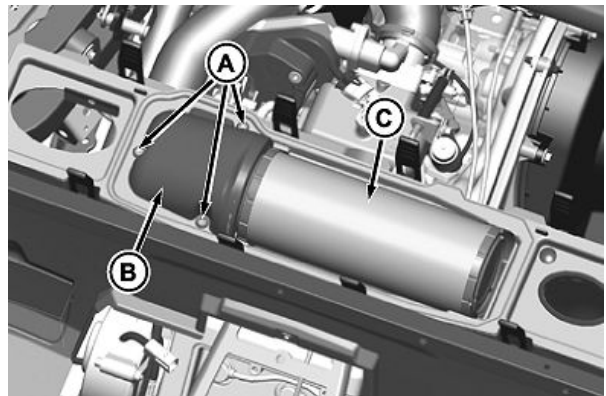

MXT016388—UN—05NOV15

MX52301,0000F5C -19-30JUN16-6/7

4. Remove three screws (A) from air plenum.
5. Disconnect air intake hose (B) from air plenum.
6. **Bucket Seat Models:** Remove air plenum from machine.

A—Screw

B—Hose, Air Intake

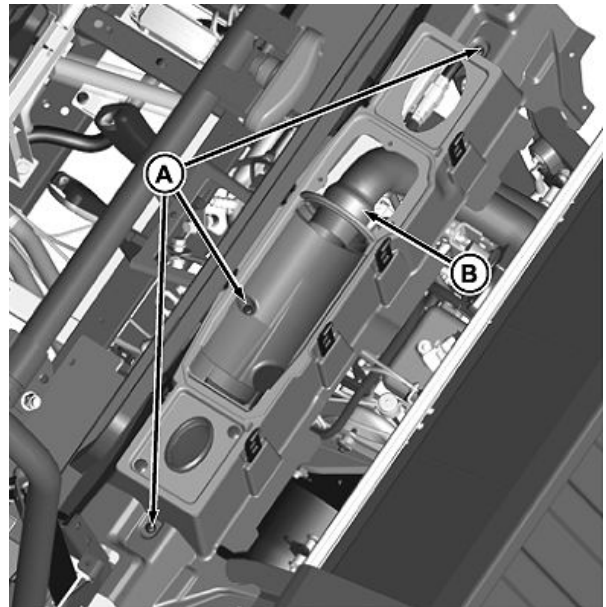

MXT016389—UN—05NOV15

MX52301,0000F5C -19-30JUN16-7/7

## Remove Protective Structure

**⚠ CAUTION: Avoid Injury! Machine component or attachment is heavy. Use a safe lifting device or get an assistant to help lift, install or remove component or attachment.**

### XUV550 and XUV560

1. Disconnect wiring harness connector (A)
2. Remove locknut (B) and seat belt retractor (C) from machine.
3. Remove three locknuts (D) and lower seat belt anchor from machine.
4. Repeat for other side.
5. **Bench Seat Models:** Remove seat back bracket (E) and air plenum from machine.

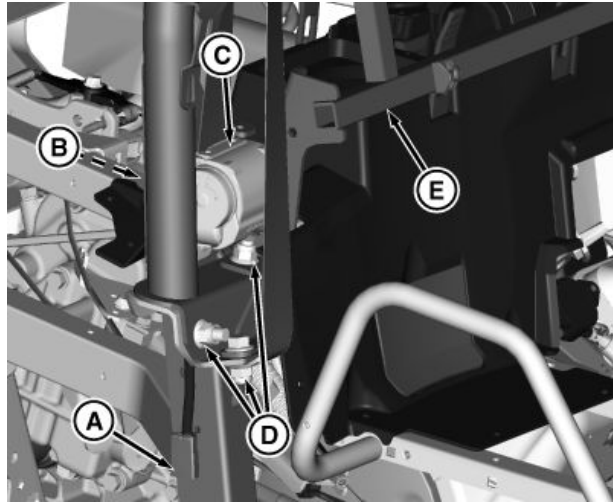

A—Connector, Wiring Harness      D—Locknut, M12  
 B—Locknut, M12                      E—Seat Back Bracket (Bench  
 C—Seat Belt Retractor              Seats Models)

MXT018687 — UN—24JUN16

MX52301,0000F88 -19-12JUL16-1/6

6. Remove four locknuts (A) and bolts from front of Protective Structure uprights.
7. Support and move Protective Structure forward to clear dashboard rear panel (B).
8. Discard Protective Structure and mounting hardware.

A—Locknut, M12                      B—Panel, Dashboard

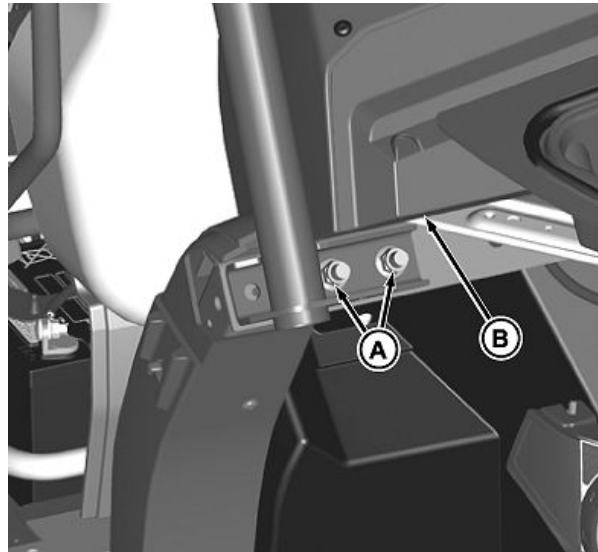

MXT016893 — UN—05NOV15

Continued on next page

MX52301,0000F88 -19-12JUL16-2/6



**XUV590i**

1. Remove locknut (A) and seat belt retractor (B).
2. Remove bolt, locknut (C), and lower seat belt anchor (D) from machine.

A—Locknut, M12  
B—Retractor, Seat Belt

C—Locknut, M12  
D—Anchor, Lower Seat Belt

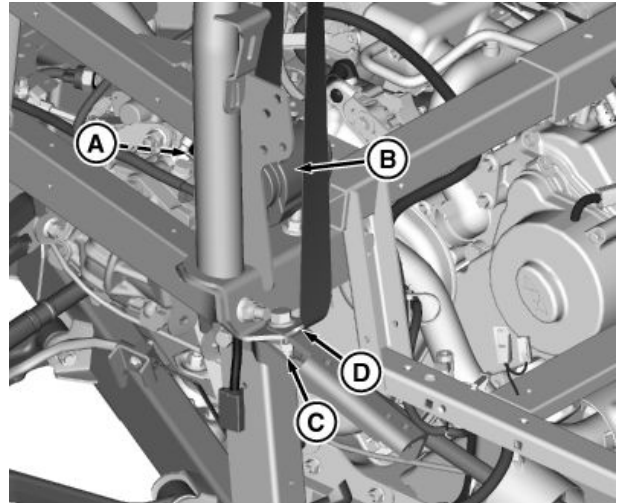

MXT018684—UN—07JUL16

MX52301,0000F88 -19-12JUL16-3/6

3. Disconnect wiring harness connector (A).
4. Remove two M12 locknuts (B) and bolts from machine.
5. Repeat for other side.
6. **Bench Seats Models:** Remove bench seat back bracket (C) and air plenum from machine.

A—Connector, Wiring Harness    C—Seat Back Bracket  
B—Bolt, M12x35

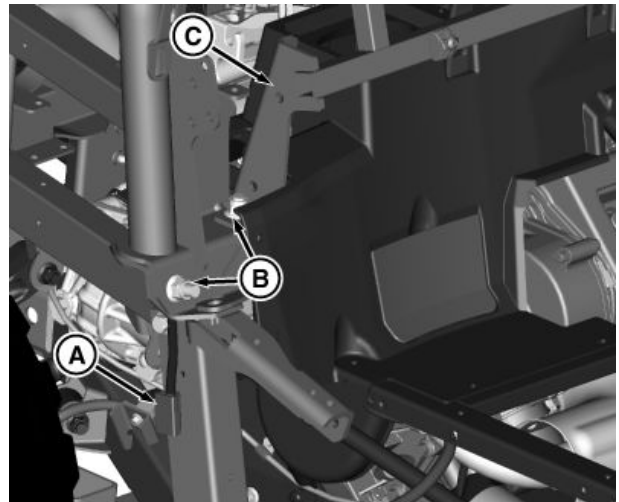

MXT018685—UN—08JUL16

Continued on next page

MX52301,0000F88 -19-12JUL16-4/6

- Remove hoses (A) from left rear protective structure frame (B).

A—Hose

B—Protective Structure Frame,  
Left Rear

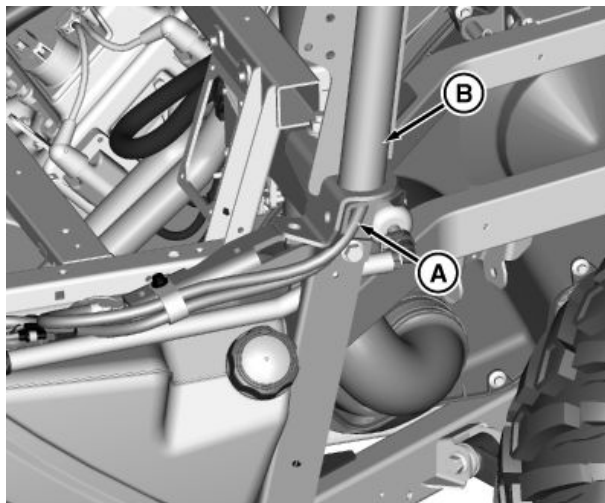

MXT016690 —JUN—08JUL16

MX52301,0000F88 -19-12JUL16-5/6

- Remove four locknuts (A) and bolts from front Protective Structure uprights.
- Support and move Protective Structure forward to clear dashboard panel (B).
- Discard Protective Structure and mounting hardware.

A—Locknut, M12

B—Panel, Dashboard

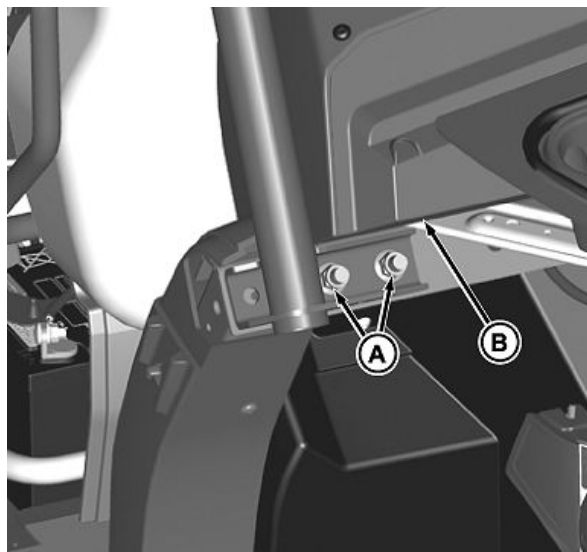

MXT016393 —JUN—05NOV15

MX52301,0000F88 -19-12JUL16-6/6

### Assemble Protective Structure Frame

**⚠ CAUTION: Avoid injury! Machine component or attachment is heavy. Use a safe lifting device or get an assistant to help lift, install, or remove component or attachment.**

1. Loosely install front cross tube (A) on side frames (B) with four bolts (C) and locknuts (D) (on top), as shown.

A—Cross Tube, Front  
B—Frame, Side

C—Bolt, M12x30  
D—Locknut, M12

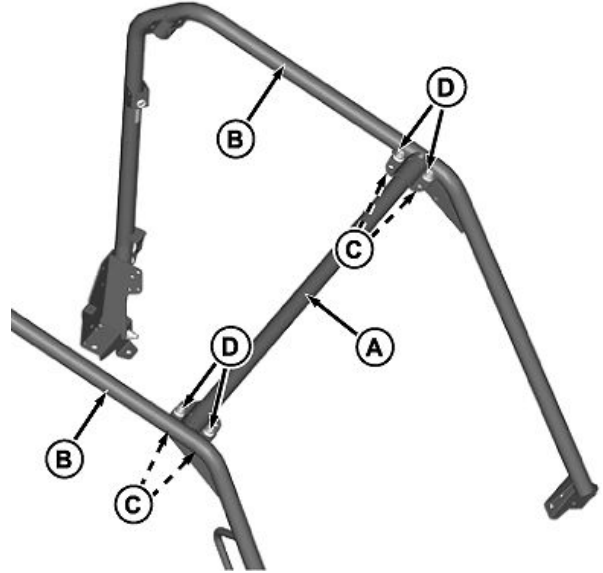

MXT016394—UN—05NOV15

MX52301,0000F4E -19-08JUL16-1/3

2. Route rear Protective Structure lights wiring harness (A) through rear cross tube (B) and right side frame (C).
3. Connect wiring harness to rear Protective Structure light (D) and install to rear cross tube with screws (E) and nuts (F).

A—Wiring Harness, Rear Protective Structure Lights  
B—Cross Tube, Rear  
C—Side Frame, Right

D—Light, Rear Protective Structure  
E—Screw, M5x30  
F—Nut, M5

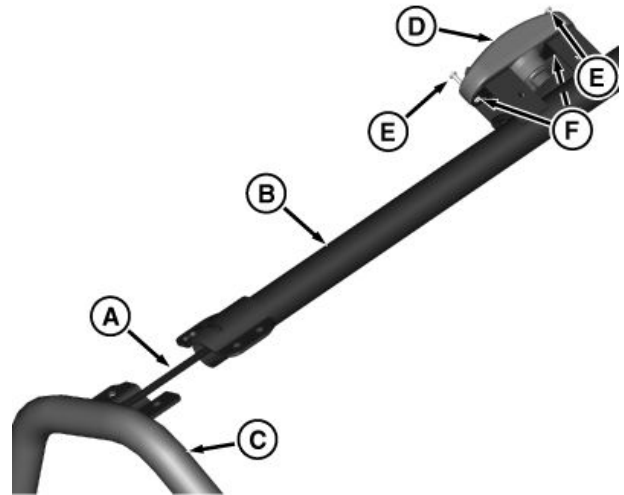

MXT018692—UN—08JUL16

Continued on next page

MX52301,0000F4E -19-08JUL16-2/3

- Loosely install rear cross tube (A) to side frames (B) with four bolts (C) and locknuts (D) (on top) as shown.

A—Cross Tube, Rear  
B—Side Frame

C—Bolt, M12x30  
D—Locknut, M12

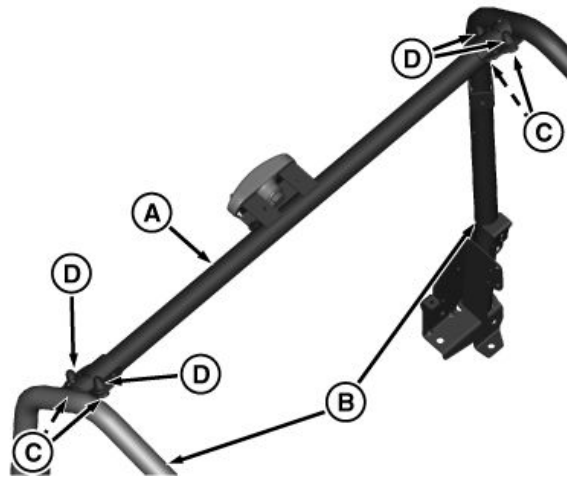

MXT018693 —UN—08JUL16

MX52301,0000F4E -19-08JUL16-3/3

### Install Protective Structure Frame

**⚠ CAUTION: Avoid Injury! Machine component or attachment is heavy. Use a safe lifting device or get an assistant to help lift, install or remove component or attachment.**

- Position Protective Structure with front mounting brackets below dashboard panel (A).
- Align mounting holes and loosely install four bolts with locknuts (B) attaching Protective Structure to frame.

A—Panel, Dashboard

B—Locknut, M12

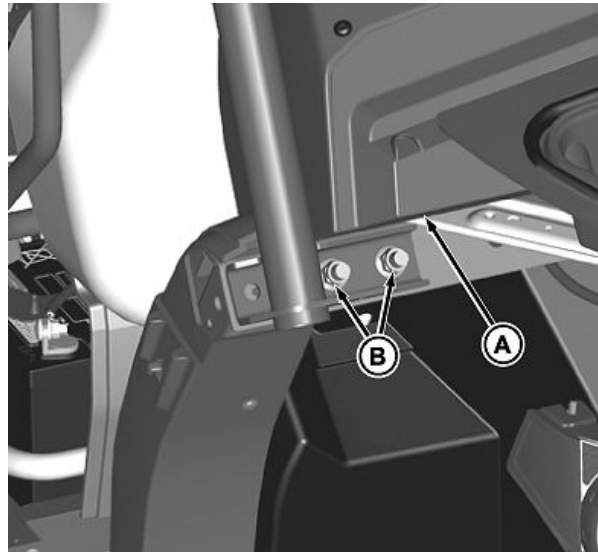

MXT016396 —UN—05NOV15

Continued on next page

MX52301,0000F5D -19-13JUL16-1/5

3. **For machines with a bench seat:** Install the Protective Structure under seat back mounting bracket (A) before installing hardware.

**A—Seat Back Mounting Bracket**

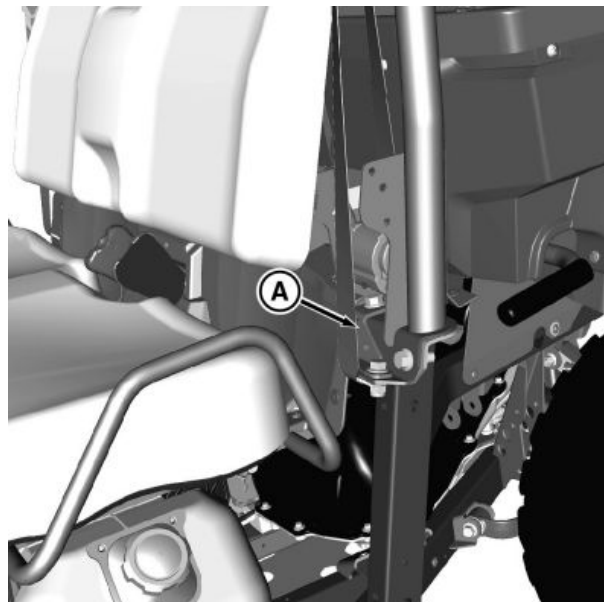

XUV550 and XUV560 Shown

MX52301,0000F5D -19-13JUL16-2/5

MXT004497 —UN—20JUN12

### XUV550 and XUV560

1. Align mounting holes and install bolt with locknut (A). Tighten to 125 N·m (92 lb-ft).
2. **For machines with a bench seat:** Loosely install air plenum (B) and seat back bracket (C) to machine.
3. Install bolt with washer under frame, and locknut (D) on top. Tighten to 125 N·m (92 lb-ft).
4. Repeat for other side.
5. If installed, connect Protective Structure brake light wiring harness connector (E).
6. Tighten all front Protective Structure attachment bolts to 125 N·m (92 lb-ft).
7. Tighten all twenty M12 locknuts on Protective Structure to 125 N·m (92 lb-ft).
8. Install kits removed earlier onto new Protective Structure.

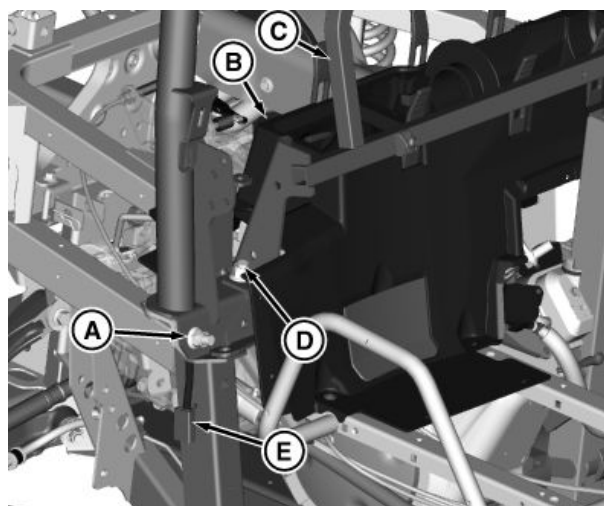

Shown With Bench Seat Option

<b>A—Locknut</b>	<b>D—Bolt</b>
<b>B—Air Plenum</b>	<b>E—Brake Light Wiring Harness Connector</b>
<b>C—Seat Back Bracket (Bench Seats Only)</b>	

Continued on next page

MX52301,0000F5D -19-13JUL16-3/5

MXT018584 —UN—24JUN16

**XUV590i**

1. Align mounting holes and install bolt with locknut (A). Tighten to 125 N·m (92 lb·ft).
2. **For machines with a bench seat:** Loosely install air plenum (B) and seat back bracket (C) to machine.
3. Install bolt with washer under frame, and locknut (D) on top. Tighten to 125 N·m (92 lb·ft).
4. Repeat for other side.
5. Connect Protective Structure brake light wiring harness connector (E).
6. Tighten all M12 hardware to 125 N·m (92 lb·ft).

- |  |   |
|--|---|
| <b>A</b> —Locknut, M12                         | <b>D</b> —Locknut, M12                          |
| <b>B</b> —Air Plenum                           | <b>E</b> —Connector, Brake Light Wiring Harness |
| <b>C</b> —Seat Back Bracket (Bench Seats Only) |   |

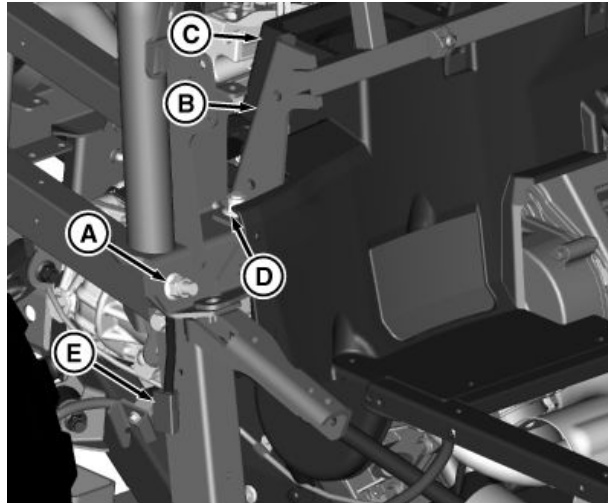

*Shown With Bench Seat Option*

MXT018686—UN—06JUL16

MX52301,0000F5D -19-13JUL16-4/5

7. Lubricate hoses (A) with soapy water and install into left rear protective structure frame (B).
8. Install kits removed earlier onto new Protective Structure.

- |                |   |
|----------------|---|
| <b>A</b> —Hose | <b>B</b> —Protective Structure Frame, Left Rear |
|----------------|---|

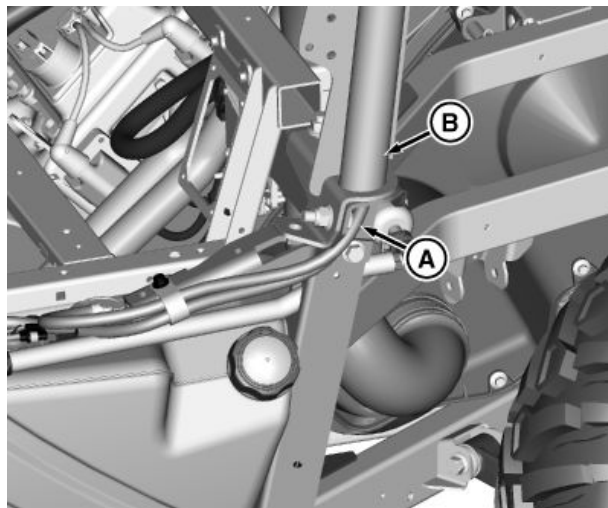

MXT018687—UN—07JUL16

MX52301,0000F5D -19-13JUL16-5/5

### Assemble Seat Belts

1. Install seat belt retractor (A) onto Protective Structure frame (B) with locknut (C). Tighten locknut to 125 N·m (92 lb·ft).
2. Install lower seat belt bracket:
  - XUV550 and XUV560: Install lower seat belt bracket (D) to seat belt anchor assembly (E) with flange bolt (F) and locknut (G). Tighten locknut to 125 N·m (92 lb·ft).
  - XUV590i: Install lower seat belt bracket (D) to seat belt anchor assembly (E) with flange bolt (F) and locknut (G). Tighten locknut to 125 N·m (92 lb·ft).

A—Retractor, Seat Belt	E—Seat Belt Anchor Assembly
B—Frame, Protective Structure	F—Flange Bolt, M12x35
C—Locknut, M12	G—Locknut, M12
D—Bracket, Lower Seat Belt	

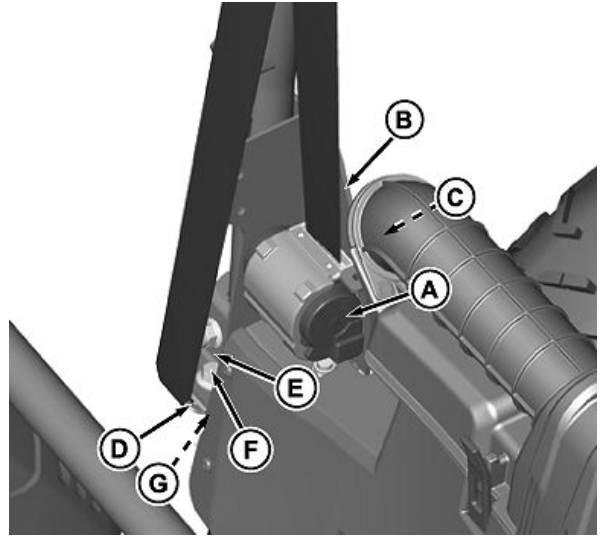

XUV550 and XUV560

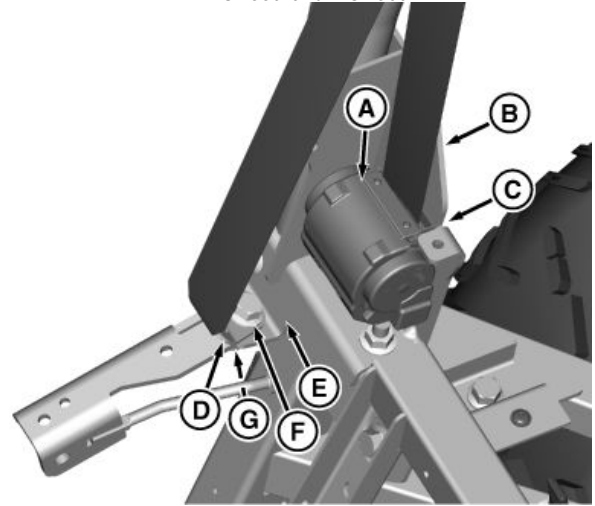

XUV590i

Continued on next page

MX52301,0000F5E -19-13JUL16-1/4

MXTO16618—UN—30NOV15

MXTO18688—UN—08JUL16

3. Install shoulder bolt (A) through seat belt anchor (B), wave spring (C), and Protective Structure bracket with locknut (D).
4. Tighten locknut to 70 N·m (52 lb·ft).
5. Install snap-on cover (E).
6. Repeat for other side.
7. Remove and discard existing seat belt buckles and hardware.

A—Shoulder Bolt, M12x32      D—Locknut, M12  
 B—Anchor, Upper Seat Belt      E—Cover, Snap-On  
 C—Spring, Wave

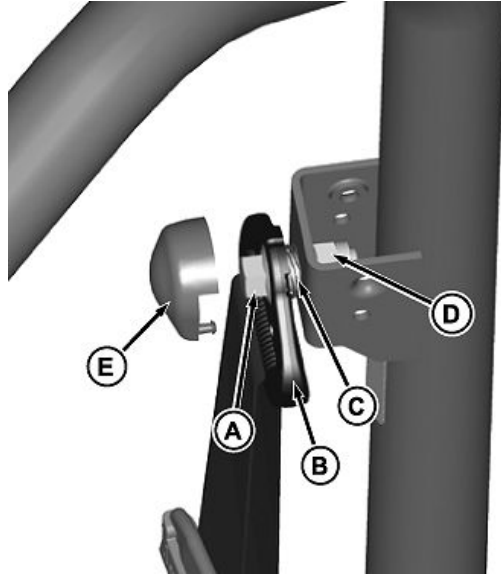

MXTO16399—UN—12NOV15

MX52301,0000F5E -19-13JUL16-2/4

8. XUV550 only:

**IMPORTANT: Avoid damage! Hex head bolts must be installed up and through the bracket, with the locknut on the top of the bracket.**

*NOTE: XUV550 models require installation of two (2) M12x30 hex head bolts for buckle installation rather than M12x32 shouldered flange bolts used in XUV560i and XUV590i models.*

- a. Install bolt (A) through bracket (B).
- b. Install seat belt buckle (C) to hex head bolt with locknut (D).
- c. Repeat for other side.

*NOTE: XUV550 Models: Orient buckles before tightening locknuts (C).*

- d. Tighten locknuts to 70 N·m (52 lb·ft).

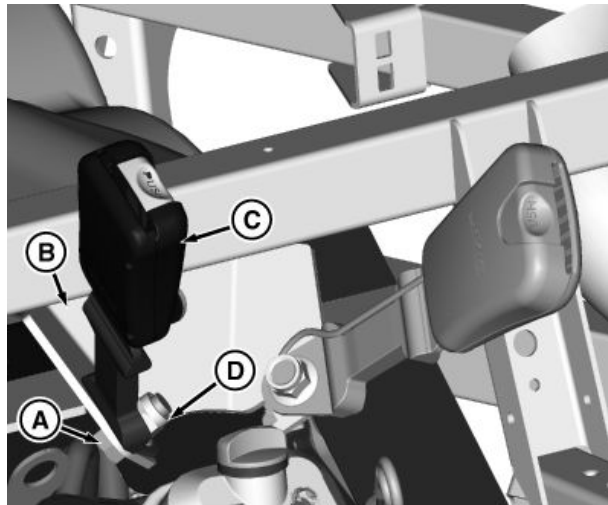

A—Hex Head Bolt, M12x30      C—Seat Belt Buckle  
 B—Bracket      D—Locknut

MXTO16681—UN—13JUL16

Continued on next page

MX52301,0000F5E -19-13JUL16-3/4



**IMPORTANT: Avoid damage! Flange bolts must be installed down and through the bracket, with the locknut on the bottom of the bracket.**

9. XUV560 and XUV590i only:
  - a. Install seat belt buckle (A) to machine bracket (B) with flanged shoulder bolt (C) as shown.
  - b. Repeat for other side.
  - c. Install locknuts (D) to flanged shoulder bolts and tighten locknuts to 70 N·m (52 lb-ft).
10. Connect seat belt buckle wiring harness connector to machine wiring harness.

A—Seat Belt Buckle  
B—Bracket

C—Flanged Shoulder Bolt,  
M12x32  
D—Locknut

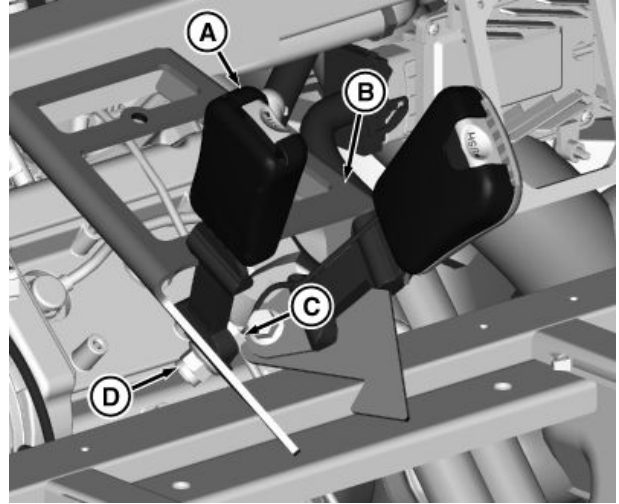

MXT018701—UN—13JUL16

MX52301.0000F5E -19-13JUL16-4/4

### Retrofit Instructions (XUV550 Only)

1. Remove 5 mm of material on service closeout panel tab (A) as shown.
2. Remove 5 mm of material on service seat closeout panel (B) as shown.
3. Remove burrs and sharp edges.

A—Service Closeout Panel Tab    B—Service Seat Closeout Panel

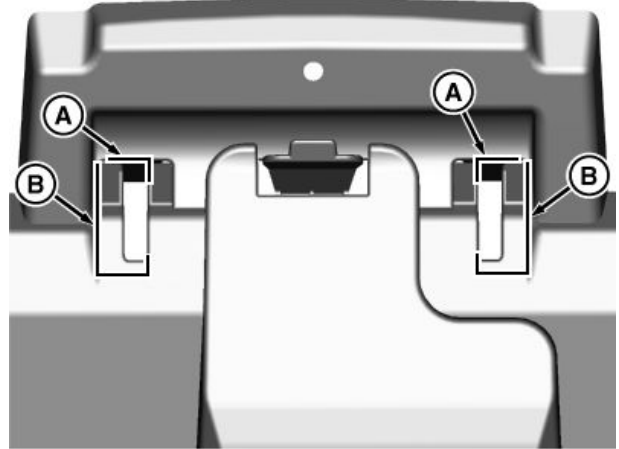

MXT018230—UN—24MAY16

MX52301.0000F87 -19-28JUN16-1/1

## Assemble Machine

### Install Air Plenum

1. Install air intake hose (A) and three screws (B).

A—Hose, Air Intake

B—Screw

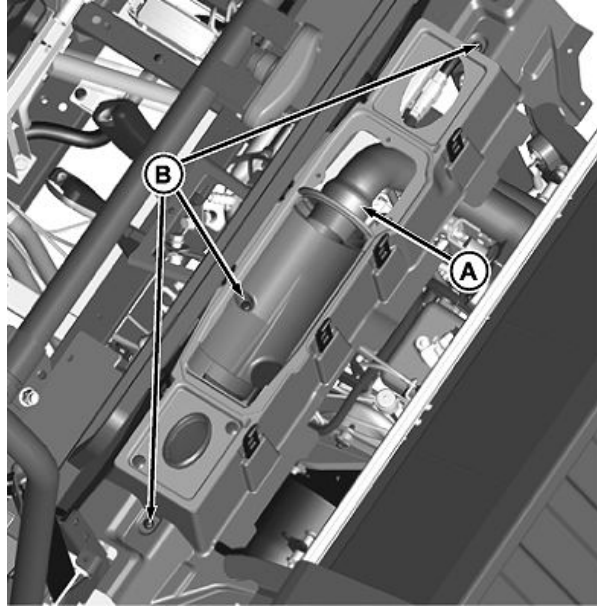

MXT016401 —UN—05NOV15

MX52301,0000F60 -19-29JUN16-1/7

2. Install air filter (A), gasket, and cover (B) with three screws (C).

A—Filter, Air  
B—Cover

C—Screw

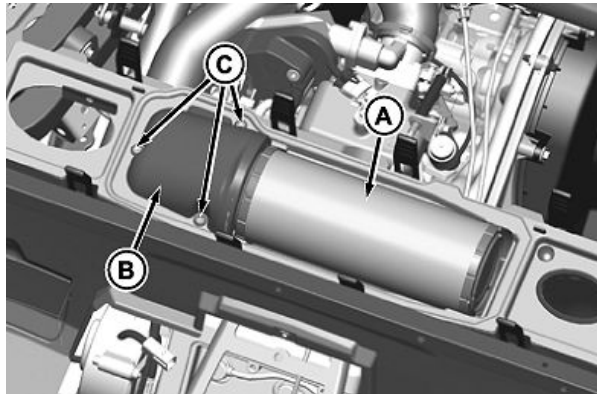

MXT016402 —UN—05NOV15

MX52301,0000F60 -19-29JUN16-2/7

3. Install air plenum cover (A) with eight tabs (B).

A—Cover, Air Plenum

B—Tab

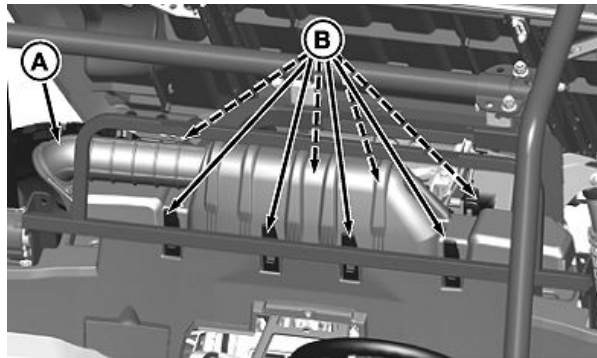

MXT016403 —UN—05NOV15

Continued on next page

MX52301,0000F60 -19-29JUN16-3/7

4. Install air plenum (A) with eleven screws (B).

A—Air Plenum

B—Screw

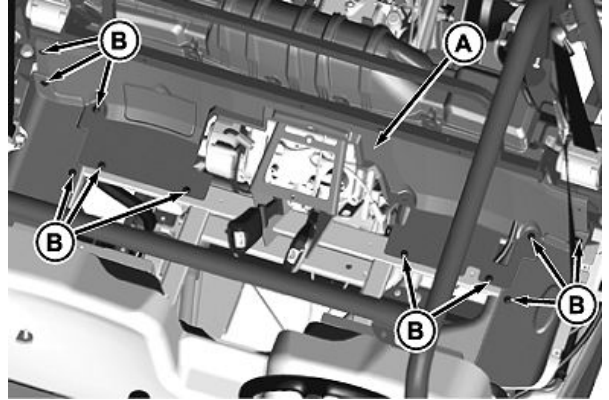

MXTO16404—UN—05NOV15

MX52301,0000F60 -19-29JUN16-4/7

### Install Center Panels

1. Install center panel (A) with seven screws (B).
2. Install cover (C).

A—Panel, Center  
B—Screw

C—Cover

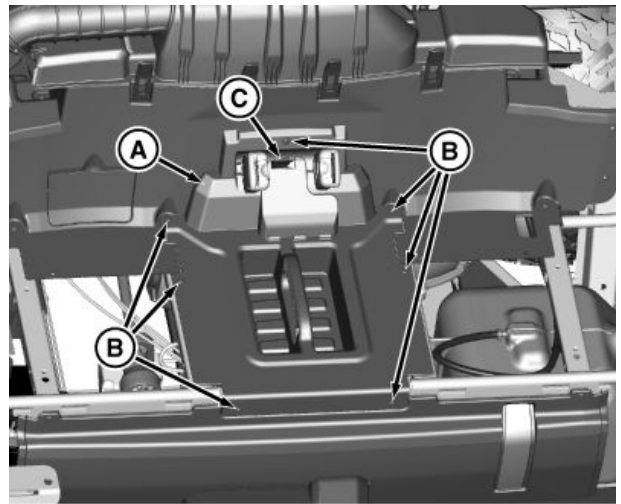

MXTO16672—UN—28JUN16

XUV550 Shown

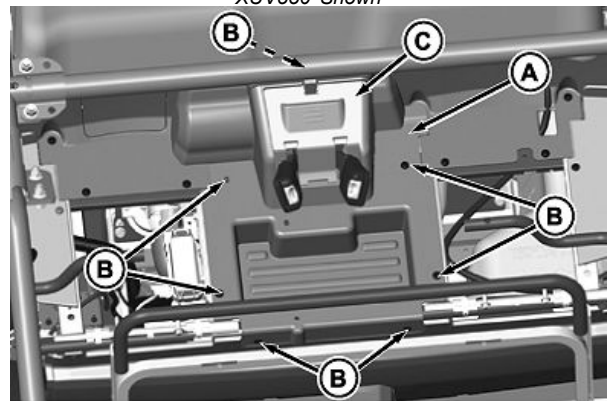

MXTO16428—UN—05NOV15

XUV560 and XUV590i Shown

Continued on next page

MX52301,0000F60 -19-29JUN16-5/7

**Install Side Panels**

**⚠ CAUTION: Avoid injury! Gasoline is extremely flammable. DO NOT SMOKE. Always work in a well-ventilated area away from open flame or spark-producing equipment, including equipment that utilizes pilot lights.**

1. Remove fuel filler cap (A).

**IMPORTANT: Avoid damage! Check to be sure that no wire harness gets pinched between frame and side panels when installing.**

2. Install left side panel (B) with five screws (XUV550 and XUV560) or six screws (XUV590i only) (C).
3. Install fuel filler cap.

A—Fuel Filler Cap  
B—Panel, Left Side

C—Screw

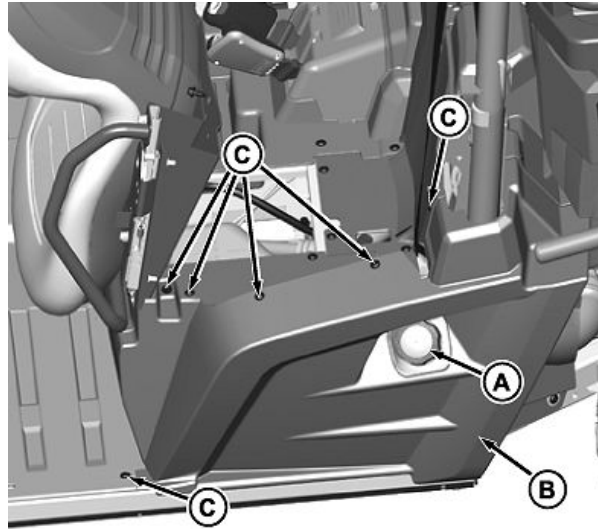

XUV590i Shown

MXTD16406 —UN—12NOV15

MX52301,0000F60 -19-29JUN16-6/7

4. Install six screws (A) in right side panel (B).
5. Install left side panel with twelve screws.
6. Lower cargo box.

A—Screw

B—Panel, Right Side

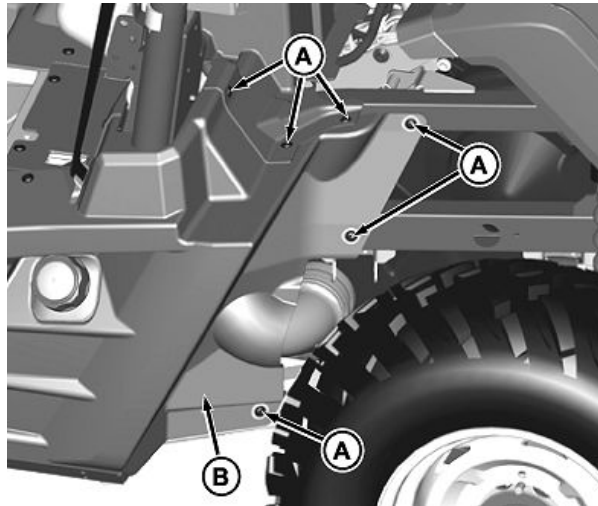

MXTD16382 —UN—05NOV15

MX52301,0000F60 -19-29JUN16-7/7

### Install Label

Install label (A) on passenger side rear Protective Structure post as shown.

To maintain occupant protection and protective structure certification:

- Replace damaged structural members and worn seatbelts. Do not repair or revise.
- Any alteration of protective structure must be approved by manufacturer.

A—Label

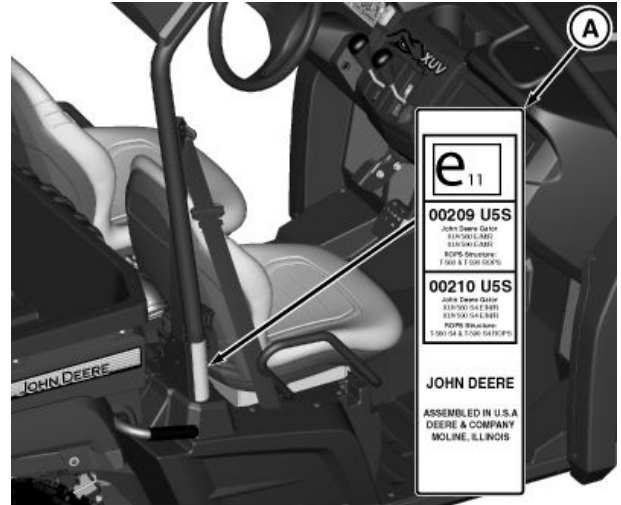

MXT020046—UN—06FEB17

MX52301,0001355 -19-06FEB17-1/1





