

Load-N-Go

BXX10241, BXX10321, and BXX10354



JOHN DEERE

INSTALLATION INSTRUCTIONS

TR108580 29OCT19 (ENGLISH)

1023E, 1025R, 2026R, 54D, 60D, 72D

John Deere Augusta Works
TR108580 (29OCT19)

PRINTED IN U.S.A.
COPYRIGHT © 2018
DEERE & COMPANY
Moline, Illinois

All rights reserved.
A John Deere ILLUSTRATION™ Manual

TR108580-19-29OCT19

Introduction

IMPORTANT:

- Read through this instruction thoroughly and familiarize yourself with the machine before installing parts.
- There is important safety information included in this installation instruction.

This installation instruction must be kept with your machine or implement operator's manual for future reference.

This instruction demonstrates the procedures for installing the Load-N-Go™ kit.

UP00731,00005E3 -19-11DEC18-1/1

Recognize Safety Information

This is a safety-alert symbol. When you see this symbol on your machine or in this manual, be alert to the potential for personal injury.

Follow recommended precautions and safe operating practices.

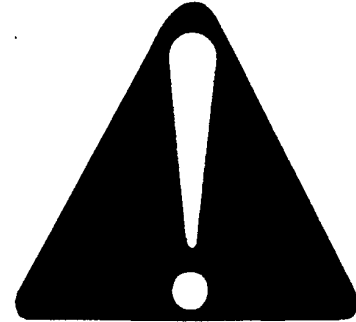

T81389 —UN—28JUN13

DX,ALERT -19-29SEP98-1/1

Understand Signal Words

DANGER; The signal word DANGER indicates a hazardous situation which, if not avoided, will result in death or serious injury.

WARNING; The signal word WARNING indicates a hazardous situation which, if not avoided, could result in death or serious injury.

CAUTION; The signal word CAUTION indicates a hazardous situation which, if not avoided, could result in minor or moderate injury. CAUTION may also be used to alert against unsafe practices associated with events which could lead to personal injury.

A signal word—DANGER, WARNING, or CAUTION—is used with the safety-alert symbol. DANGER identifies the most serious hazards. DANGER or WARNING safety signs are located near specific hazards. General



precautions are listed on CAUTION safety signs. CAUTION also calls attention to safety messages in this manual.

TS187 —19—30SEP88

DX,SIGNAL -19-05OCT16-1/1

Follow Safety Instructions

Carefully read all safety messages in this manual and on your machine safety signs. Keep safety signs in good condition. Replace missing or damaged safety signs. Be sure new equipment components and repair parts include the current safety signs. Replacement safety signs are available from your John Deere dealer.

There can be additional safety information contained on parts and components sourced from suppliers that is not reproduced in this operator's manual.

Learn how to operate the machine and how to use controls properly. Do not let anyone operate without instruction.

Keep your machine in proper working condition. Unauthorized modifications to the machine may impair the function and/or safety and affect machine life.



TS201—UN—15APR13

If you do not understand any part of this manual and need assistance, contact your John Deere dealer.

DX,READ -19-16JUN09-1/1

Replace Safety Signs

Replace missing or damaged safety signs. Use this operator's manual for correct safety sign placement.

There can be additional safety information contained on parts and components sourced from suppliers that is not reproduced in this operator's manual.

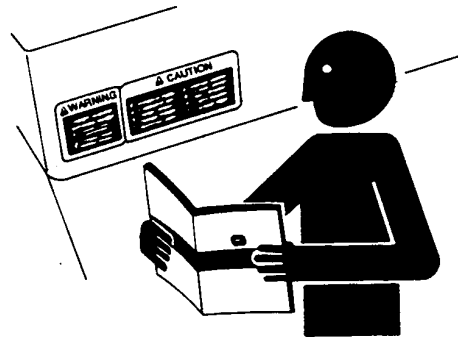

TS201—UN—15APR13

DX,SIGNS -19-18AUG09-1/1

Service Loader Safely

Always engage parking brake or place transmission in **PARK**, lower loader to the ground, shut off tractor engine and remove key before servicing the loader.

Do not walk or perform service under a raised loader, bucket or attachment unless it is securely blocked or held in position. (See SERVICE LOADER AND/OR TRACTOR SAFELY [LOADER ATTACHED] in Service section.)

Keep all parts in good condition and properly installed. Repair any damage immediately and repair or replace any worn or broken parts.

Before disconnecting hydraulic hoses, relieve all hydraulic pressure. (See procedure in your tractor Operator's Manual and RELIEVE HYDRAULIC PRESSURE SAFELY in Service section.)

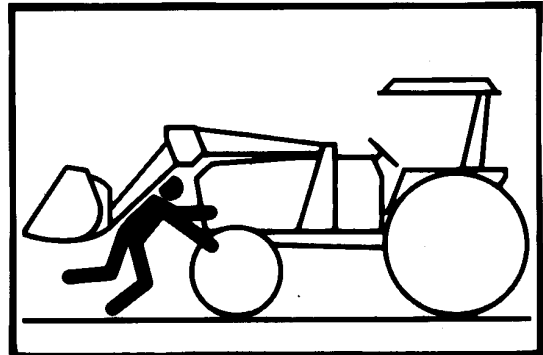
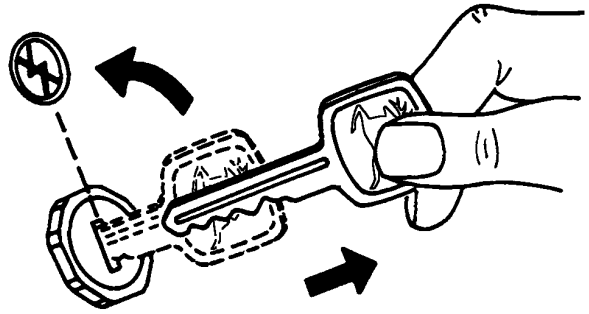

DX,WW,LOADER15 -19-18SEP12-1/1

TS1713—UN—10JUL12

TS1714—UN—10JUL12

Practice Safe Maintenance

Understand service procedure before doing work. Keep area clean and dry.

Never lubricate, service, or adjust machine while it is moving. Keep hands, feet, and clothing away from power-driven parts. Disengage all power and operate controls to relieve pressure. Lower equipment to the ground. Stop the engine. Remove the key. Allow machine to cool.

Securely support any machine elements that must be raised for service work.

Keep all parts in good condition and properly installed. Fix damage immediately. Replace worn or broken parts. Remove any buildup of grease, oil, or debris.

On self-propelled equipment, disconnect battery ground cable (-) before making adjustments on electrical systems or welding on machine.

On towed implements, disconnect wiring harnesses from tractor before servicing electrical system components or welding on machine.

Falling while cleaning or working at height can cause serious injury. Use a ladder or platform to easily reach each location. Use sturdy and secure footholds and handholds.



DX,SERV -19-28FEB17-1/1

TS218—UN—23AUG88

Park Machine Safely

Before working on the machine:

- Lower all equipment to the ground.
- Stop the engine and remove the key.
- Disconnect the battery ground strap.
- Hang a "DO NOT OPERATE" tag in operator station.

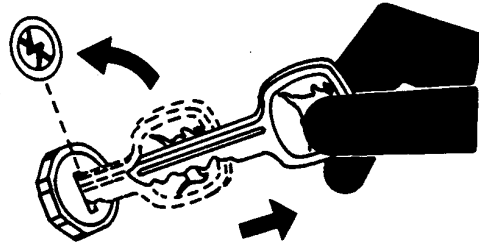

TSS230 —UN—24MAY89

DX,PARK -19-04JUN90-1/1

Kit Parts List
60" Deck

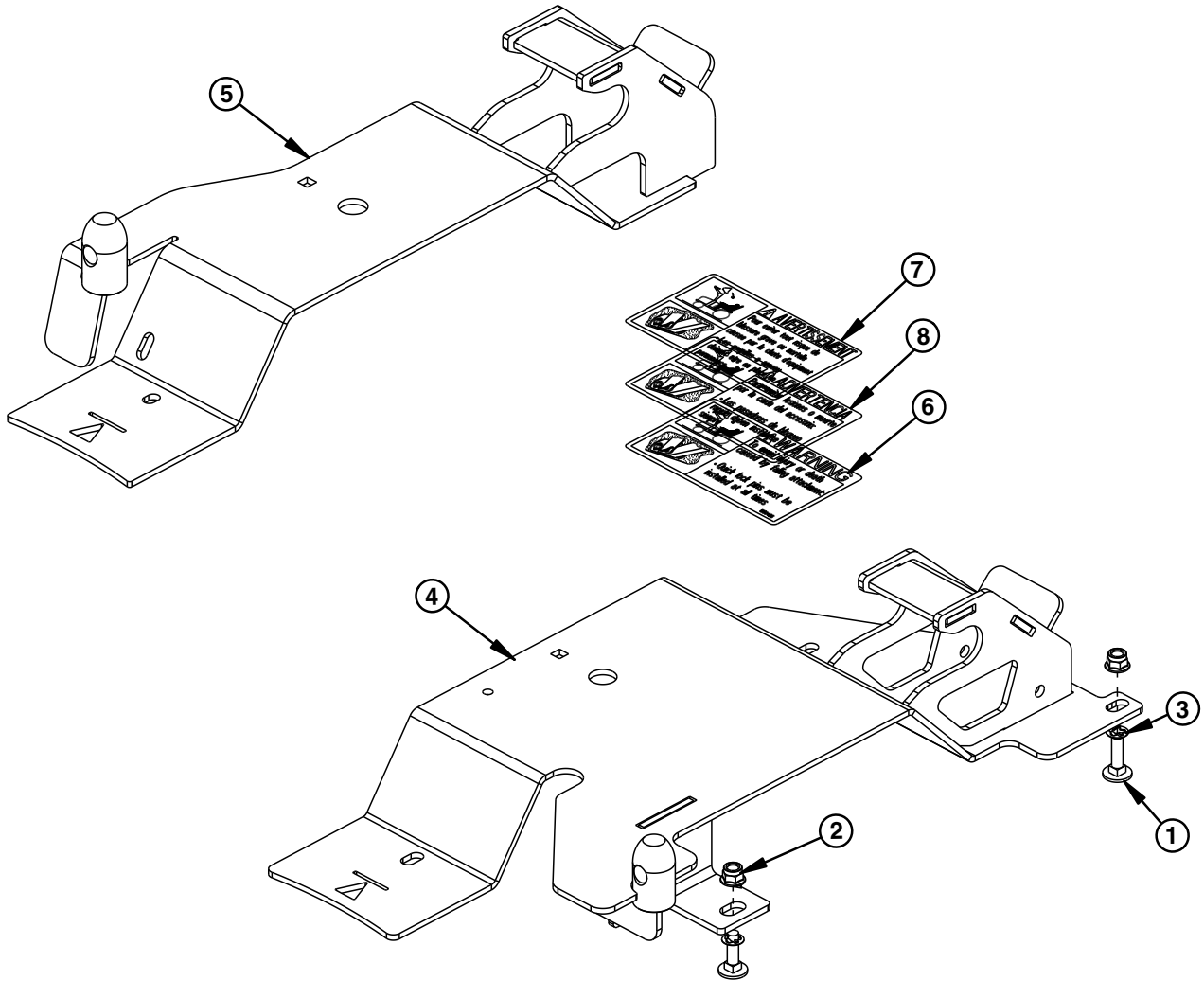

LVP10111—UN—17OCT19

Kit Parts List - BXX10241 (60" Deck)

Item	Part Number	Description	Quantity
1	03M7094	Bolt M8 x 1.25 x 30	2
2	14M7396	Locking Nut M8 x 1.25	2
3	M84309	Nut	2
4	TA11797	Right Ramp Assembly (60" Deck)	1
5	TA14091	Left Ramp Assembly (60" Deck)	1
6	W50426	Warning Label	1
7	W51586	Warning Label, French	1
8	W51590	Warning Label, Spanish	1

Continued on next page

PS75950,0000908 -19-24OCT19-1/2

54" and 72" Deck

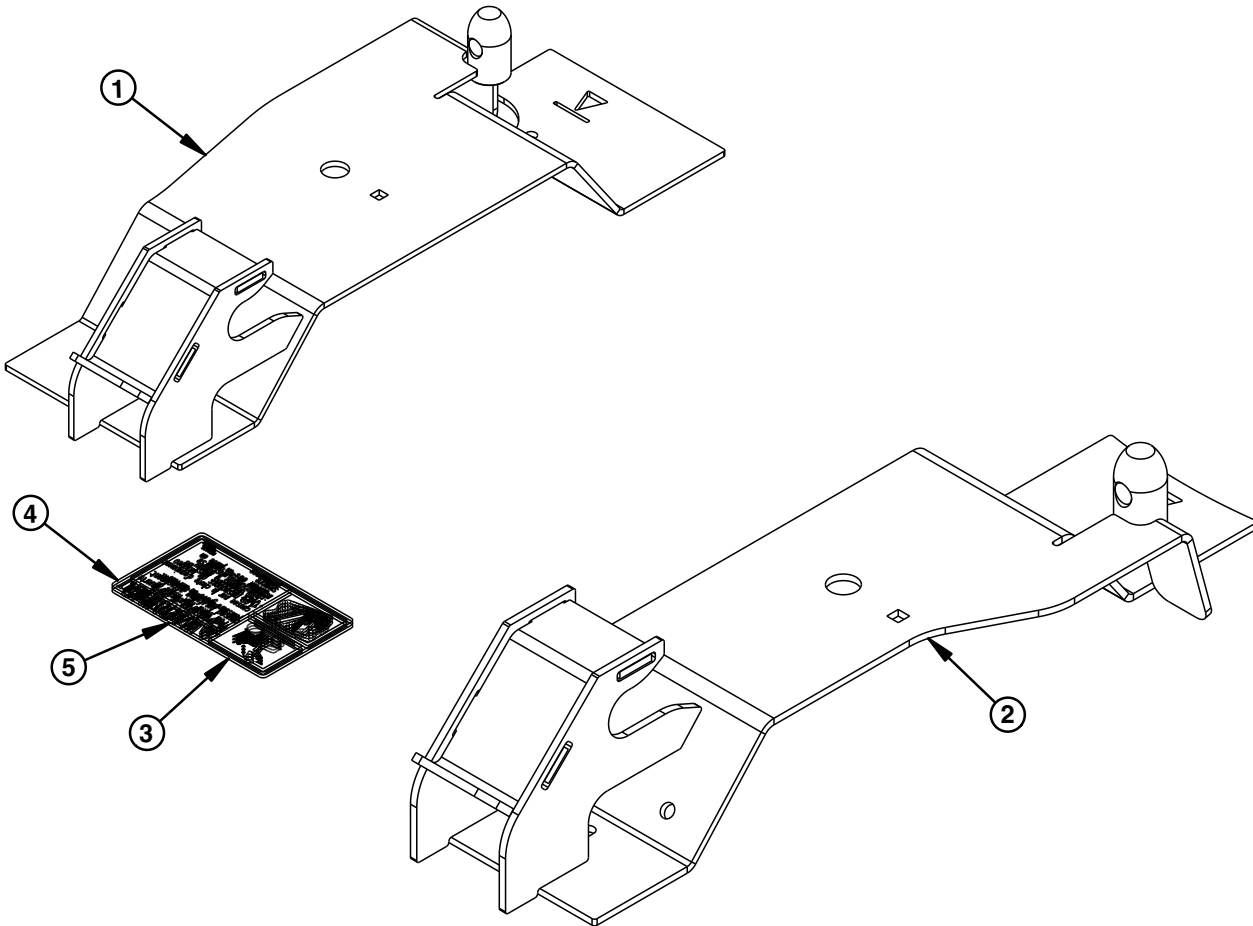

LVP10112—UN—17OCT19

Kit Parts List - BXX10321, BXX10354 (54" and 72" Deck)

Item	Part Number	Description	Quantity
1	TA13461	Right Ramp Assembly (54" Deck)	1
1	TA14345	Right Ramp Assembly (72" Deck)	1
2	TA13462	Left Ramp Assembly (54" Deck)	1
2	TA14091	Left Ramp Assembly (72" Deck)	1
3	W50426	Warning Label	1
4	W51586	Warning Label, French	1
5	W51590	Warning Label, Spanish	1

PS75950,0000908 -19-24OCT19-2/2

Remove Drive-Over Ramps

1. Remove the four nuts (A) that are securing the ramps to the mower deck. Save the nuts for later. Remove the ramps from the mower deck.

A—Nuts

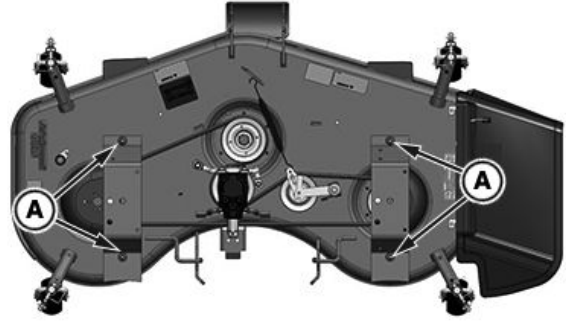

LV30380—UN—22OCT18

PS75950,0000906 -19-22OCT19-1/3

2. **For 60D Only:** Remove the two lock nuts (A) that are securing the discharge chute to the mower deck. Save the nuts for later use. Remove the discharge chute

A—Lock Nut

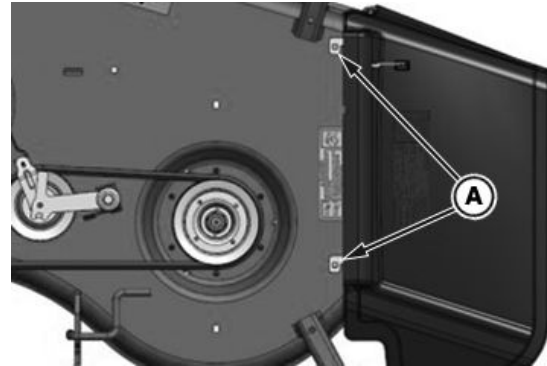

LV30381—UN—22OCT18

PS75950,0000906 -19-22OCT19-2/3

3. To remove the spindle cover from the ramps, hold securely and remove the cap screw (A), nut, and self-tapping screw (B).

NOTE: Remove tire guide (if not welded) from the mower deck and install on the Load N Go ramp.

4. Repeat for both sides.
5. Save the hardware for later use.

A—Cap Screw

B—Self-Tapping Screw

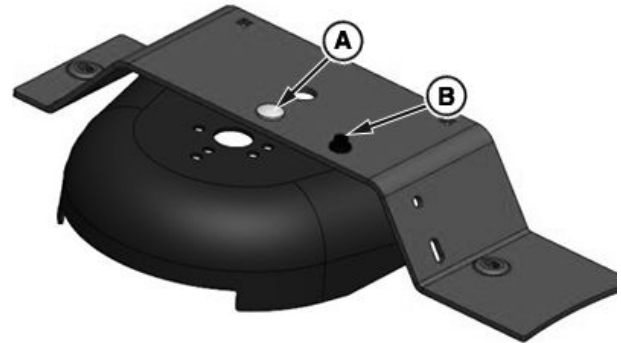

LV30382—UN—22OCT18

PS75950,0000906 -19-22OCT19-3/3

Assemble Load-N-Go Ramps

For both ramps:

1. Install spindle cover on the Load-N-Go ramp . Hold securely and secure with carriage bolt (A), nut, and self-tapping screw (B).
2. Repeat for both ramps.
3. Torque to specification.

Specification

Carriage Bolt, nut and self-tapping screw—Torque.....24 N-m
18 lb-ft

A—Carriage Bolt

B—Self-Tapping Screw

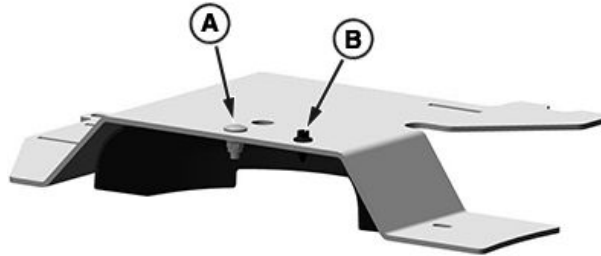
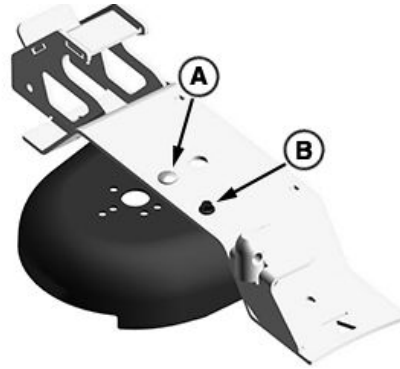

60D Ramps are shown, other models are similar

PS75950,000090D -19-11OCT19-1/1

LV30383 —UN—14NOV18

LV30384 —UN—22OCT18

Install Load-N-Go Ramps

1. Install the left ramp onto the two mower deck carriage bolts.
2. Secure the ramp to the mower deck using two lock nuts (A).

A—Lock Nut (2 used)

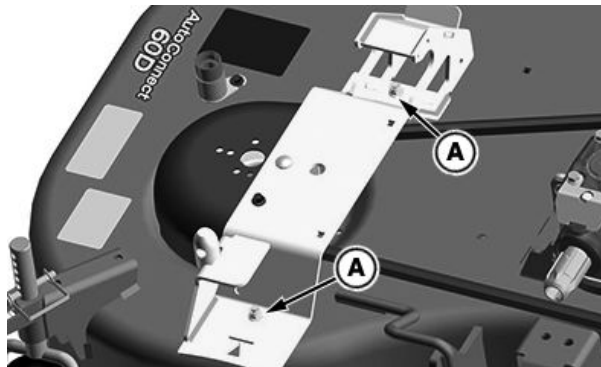

Left Ramp

Continued on next page

PS75950,0000907 -19-23OCT19-1/5

LV30386 —UN—14NOV18

3. **For 60D Only:** Remove and replace the retaining washer (A) and carriage bolt (B) on the discharge chute opening with the ones supplied in the kit.

A—Retaining Washer

B—Carriage Bolt

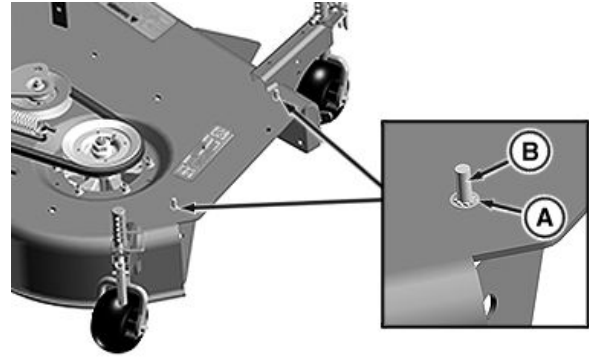

LV30385 —UN—22OCT18

PS75950,0000907 -19-23OCT19-2/5

4. Install the right ramp onto the two mower deck carriage bolts.
5. Secure the ramp to the mower deck using two lock nuts (A).

A—Lock Nut (2 used)

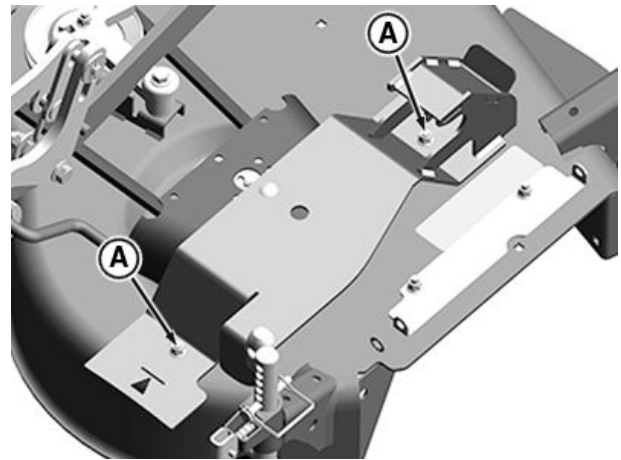

54" Deck Right Ramp (72" Similar)

LVP10114 —UN—24OCT19

PS75950,0000907 -19-23OCT19-3/5

6. **For 60D Only:** Install the right ramp on the four mower deck carriage bolts.
7. **For 60D Only:** Secure the ramp to the mower deck using two lock nuts (A). Do not torque at this time.

A—Lock Nut (2 Used)

B—Carriage Bolt

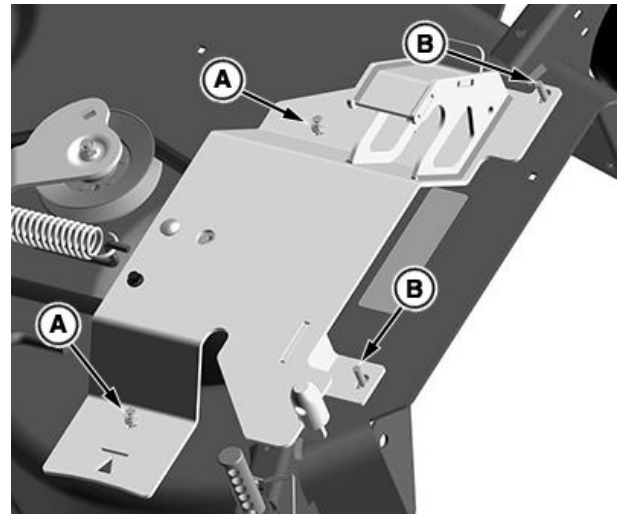

60" Deck Right Ramp

LV30387 —UN—14NOV18

Continued on next page

PS75950,0000907 -19-23OCT19-4/5

NOTE: Make sure that the torsion spring is properly installed on the discharge chute.

8. **For 60D Only:** Install the discharge chute over the ramp brackets and the two carriage bolts.
9. **For 60D Only:** Secure the ramp and discharge chute to the mower deck using two lock nuts (A).
10. **For 60D Only:** Torque all lock nuts to specification.

Specification

Lock Nut—Torque..... 17 N·m
150 lb·in

A—Lock Nut (2 Used)

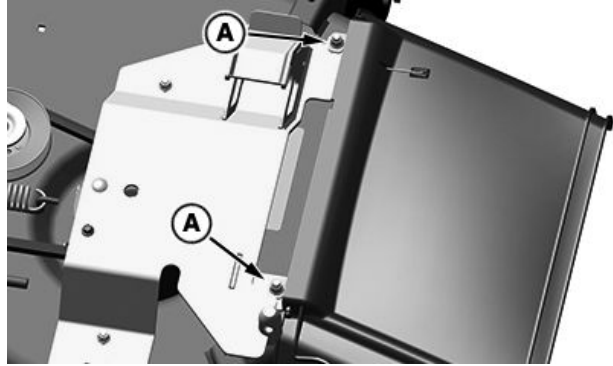

LV30403 —UN—13NOV18

PS75950,0000907 -19-23OCT19-5/5

Install Decal

NOTE: Make sure the surface where the label is placed is clean and dry, before applying the label.

Install the appropriate language safety label (A) on the mower deck in the position indicated.

- English label—W50426
- French label—W51586
- Spanish label—W51590

A—Safety Label

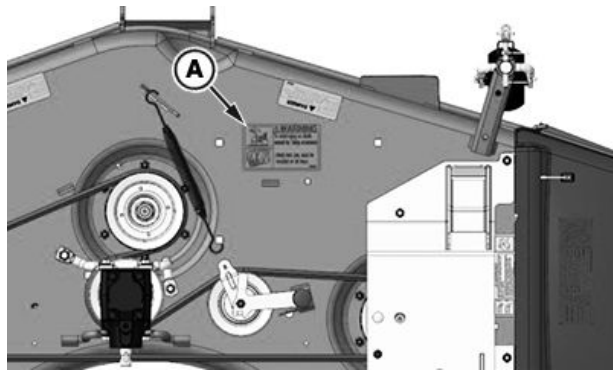

Warning Label - W50426

LV30390 —UN—23OCT18

UP00731,00005EA -19-14NOV18-1/1

Warning Label

WARNING

To avoid injury or death caused by falling attachment:

- Quick lock pins must be installed at all times.

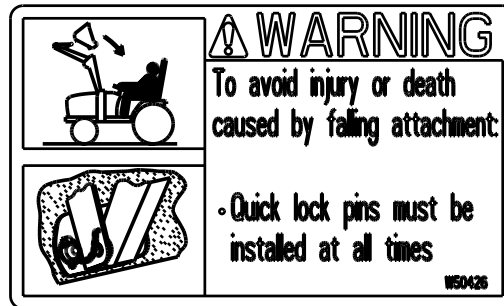

Warning Label—W50426

LV30389 —UN—24OCT18

UP00731,00005EB -19-19NOV18-1/1

Use the Load-N-Go Ramps

1. Start the tractor.
2. Extend the bucket cylinders to angle the loader carrier forward.
3. Align the holder (A) with the hooks on the mower deck (B).
4. Align and install quick-lock pins (C).

A—Holder
B—Load-N-Go Bracket

C—Quick Lock Pin

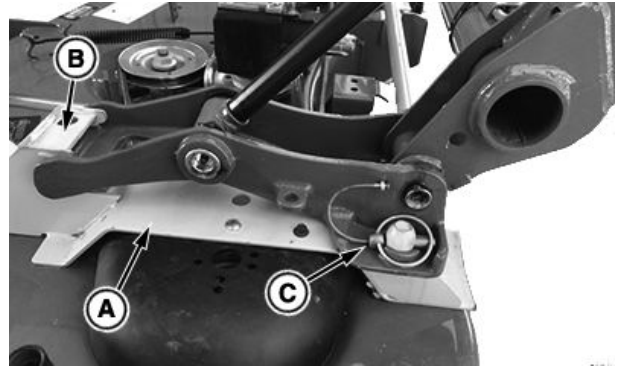

UP00731,00005EF -19-08NOV18-1/1

LV30396—UN—08NOV18

Service the Mower Deck Using the Load-N-Go Ramps

⚠ CAUTION: Do not walk or perform service under a raised loader, bucket or attachment unless it is securely blocked or held in position.

1. Start tractor engine.
2. With the mower deck attached to the loader arms, raise the mower deck off the ground.
3. Retract the cylinders to angle the mower deck in a vertical position.
4. Place support stands under the deck to align with the support point (A) locations.
5. Slowly lower the mower deck onto the support stands.
6. Move the loader SCV to the float position.

A—Support Point

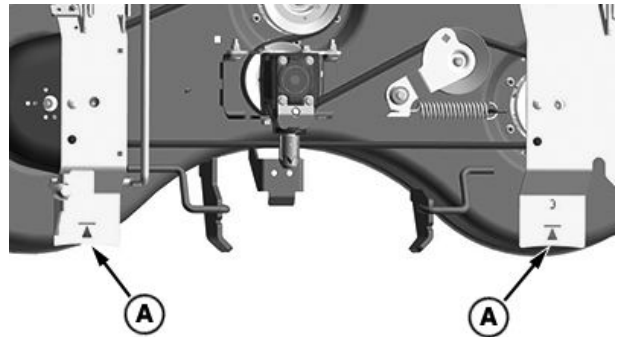

Support Point

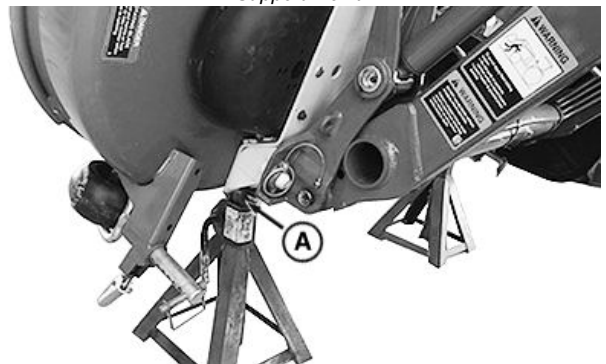

Support Point

UP00731,00005F0 -19-19NOV18-1/1

LV30404—UN—14NOV18

LV30397—UN—01NOV18

